

# Architecture of Buddhist temple



Written by Architect: Prof. Hafizullah Atm  
Date: May - June, 2025

Ketabton.com



## **Buddhist Temple in Kabul City**

### **Book specifications**

**Title:** Buddhist Temple in Kabul City

**Author:** Dr. Hashmatullah, Atmar,

**Editor:**

**Cover page design:** Dr. Hashmatullah, Atmar

**Press:**

**Number of prints:** 30

**Date of publication:** May-June/2025

**Whatsapp:** +93799376998

**Email address:** atmar\_hashmatullah@yahoo.com

### **Note:**

All rights, including rewriting, printing, duplicating, copying, translating and filming, are pursued. Quotation of the material by mentioning the source according to the accepted criteria is without hindrance.

## **Buddhist Temple in Kabul City**

### **Contents**

<b>Title</b>	<b>Page</b>
First cover page.....	1
On the name of God.....	2
Book specifications.....	3
Contents.....	4
Introduction: .....	5
Location picture .....	8
Preface: .....	9
Buddhist architecture: .....	11
Sources:.....	54
Published book list.....	55
Books in progress.....	61
If time and possible.....	62
Last Cover page .....	63

## Buddhist Temple in Kabul City

### Introduction:

الحمد لله رب العالمين والعاقبة للمتقين ولا عدوان إلا على الظالمين، والصلاة والسلام على خاتم النبيين، وعلى آله وأصحابه أجمعين، ومن تبعهم بإحسان إلى يوم الدين وبعد :

(إِنَّ الدِّينَ عِنْدَ اللَّهِ الْإِسْلَامُ) (وَمَنْ يَتَّبِعْ غَيْرَ الْإِسْلَامِ دِينًا فَلَنْ يُقْبَلَ مِنْهُ وَهُوَ فِي الْآخِرَةِ مِنَ الْخَاسِرِينَ)

"Indeed, Islam is the preferred religion before the Lord."

Whoever chooses a religion other than Islam will never be accepted, and he will be among the losers (sinners) in the hereafter.

Endless praise and limitless thanks to God Almighty, who created the world with all its secrets, full of wonders and beauties, the day for worship and work, and the night for rest so that all the tiredness of the day is removed with it. Early in the morning, wake up with the remembrance of Allah and move to obtain halal sustenance.

## **Buddhist Temple in Kabul City**

I thank you for creating the earth rich in minerals, water, and air for the survival of humans, animals, insects, and plants so that they can eat, drink, and not give up.

Humans were created by the best of creations with great intelligence and special emotions, so they are very different and the best of creations.

I am very happy that he blessed me with the last prophet and perfect religion and blessed me with good health so that I can share with my Muslim brothers the small window of knowledge and treasures he has given me.

Lord!

Make your way easy for us, so that we do not see or know anyone other than you; bring our essence and existence to the point of annihilation (destroy, annihilate); so that there is no suspicion of egoism (arrogance); let there not be pride and arrogance in our existence; and let us be your pure servants.

Dear readers!

This time, I wanted to start a new research project called "Buddhist Temple in Kabul City" and share

## **Buddhist Temple in Kabul City**

good and fruitful pictures about the temple with detailed and comprehensive maps with my book lovers and readers.

The fans of my books are not only architects and engineers; they shouldn't be, because I want to change my writings day by day so that the fans of each sector will increase.

### **Note:**

1. All experts and those who read this book are respectfully requested to share their opinions, suggestions, and criticisms with me for revising this book.

Whatsapp: 0093799376998

With respect

Dr. Hashmatullah Atmar

## **Buddhist Temple in Kabul City**



**Location picture of the temple by Google Earth**



## **Buddhist Temple in Kabul City**

### **Preface:**

Afghanistan is a landlocked country located in the heart of the Asian continent that borders China, Tajikistan, Uzbekistan, Turkmenistan, Iran, and Pakistan.

3/4 is a high mountain with rich mineral reserves.

That is why it has always attracted the attention of the world, and most of it has invaded the military powers of the region and the world and caused great blows to humans, construction, and urbanization.

The geography of Afghanistan is arid and mountainous; the Hindu Kush Mountains run northeast to southwest and divide the Northern provinces from the rest of the country. The government system is an Islamic Emirate; the chief of state and head of the Emirate is the Emir. Afghanistan has a controlled economic system in which the central emir directs the economy regarding the production and distribution of goods. Afghanistan is a member of the South Asian Association for Regional Cooperation (SAARC).

## **Buddhist Temple in Kabul City**

The architecture of Afghanistan refers to the architecture within the borders defining the modern country, with these remaining relatively unchanged since 1834.

As the connection between the three major cultural and geographic centers of Central Asia, the Indian subcontinent, and the Iranian plateau grew, the boundaries of the region prior to this time changed with the rapid advancement of armies, with the land belonging to a vast range of empires over the last two millennia.

The diversity of Afghan history allows for the diversity that exists in the country's architecture and architectural remains, with influences ranging over time from Greek to Persian to Indian to Chinese to European in recent centuries.

A range of religious influences over time is also reflected, with evidence primarily exhibiting early Buddhist, Zoroastrian, and Islamic inspiration.

## **Buddhist Temple in Kabul City**

### **Buddhist architecture:**

The arrival of the originally nomadic Kushans from Central Asia added a new element to the already eclectic nature of the architecture of Afghanistan.

The establishment of the Kushan Empire invigorated existing traditions and reasserted international connections, encouraging the spread of Buddhism into Afghanistan.

With the advent of the Iron Age in Central Asia, the first indications of circular city planning are evident, typical across the Iranian plateau from this point. The circular form most likely had defensive intent as its origin.

Parts of the major historical cities, such as Balkh and Kandahar, have evidence of ramparts with foundations dated back to this period, with characteristic mud-brick construction and towers at regular intervals.

## **Buddhist Temple in Kabul City**



**A picture of the ruins of a Buddhist temple after renovation**

## **Buddhist Temple in Kabul City**



**A picture of the way to the Buddhist temple**

## **Buddhist Temple in Kabul City**



**A picture of the way to the Buddhist temple**

## **Buddhist Temple in Kabul City**



**A picture of the ruins of a Buddhist temple after renovation**

## **Buddhist Temple in Kabul City**



**A picture of the ruins of a Buddhist temple after renovation**



## **Buddhist Temple in Kabul City**



**A picture of the ruins of a Buddhist temple after renovation**

## **Buddhist Temple in Kabul City**



**A picture of a Buddhist temple after renovation**

## **Buddhist Temple in Kabul City**



**Picture of the west entrance to the Buddhist temple**

A citadel was also commonly situated within the center of these structures, indicating that these settlements also operated as administrative centers and marketplaces.

This tradition of defensive architecture was spread and maintained across much of Central Asia from the beginning.

## **Buddhist Temple in Kabul City**



**A picture of the interior of a Buddhist temple**

## Buddhist Temple in Kabul City



Picture of measuring for a Buddhist temple

## **Buddhist Temple in Kabul City**



**Picture of the interior worship hall and entrance pundit room in a Buddhist temple**

## **Buddhist Temple in Kabul City**



**Picture of the interior worship hall in a Buddhist temple**

## **Buddhist Temple in Kabul City**



**Picture of the interior worship hall in a Buddhist temple**



**Picture of the interior worship hall in a Buddhist temple**



## **Buddhist Temple in Kabul City**



**Picture of the interior worship hall in a Buddhist temple**

## **Buddhist Temple in Kabul City**

With the establishment of the Kushan Empire, both political and dynastic centers were established, with one such dynastic center identified in Afghanistan at Surkh Kotal, established during the height of Buddhism in Afghanistan.

Excavations of the site revealed a monumental set of stairs leading down the hillside from a Kushan temple, built in the first half of the 2nd century AD.

Zoroastrian associations are possibly evident in fire worship symbols and exist alongside Buddhist architectural features.

Hellenistic pilasters and column bases alongside limestone with Greek letter inscriptions in an unknown language are evidence of Western influence, while Iranian influences may also exist within the concept of a monumental dynastic center.

Kabul City Buddhist Temple (Dargah) is one of the old and spectacular buildings of the Khwaja Safa area, and it is located on the level of Khwaja Safa Shrine on the south side of old Kabul City in the middle of Shir Darwaza (lion gate) mountain.

## **Buddhist Temple in Kabul City**

The stone building has two parts, namely, the large prayer hall, which is in the form of a rectangle (north-south) in a plan, and the long east-west rectangular part, which includes the Pundit and nine other rooms.

Each room has a separate entrance, and according to the information of the servant from the old Hindu man who had a traditional treatment shop in Shur bazar, these rooms were used as a guest house for those who came here from different provinces or distant areas for worship.

The entrances and open space for lighting were without plaster, as were all the arches, including the domes of each room.

Clay is made with lime and sand. In the prayer room towards the south (mountainside), niches have been observed, which were used for worship tools, but in the middle of this room, arches and a wall heater (fireplace) can also be observed, which indicates the existence of windows in the past.

Which has been destroyed over time, removed, or stolid by some people in the wintertime.

## **Buddhist Temple in Kabul City**

The roof of the guest and passenger rooms looks completely smooth from the top of the mountain, except for the worship room.

The worship hall has an external dome cover, and the height of the middle of the dome is 140 cm from the roof level with the small hole of the open skylight, which can be used for ventilation and light.

The wall's width is 140 cm at the base, but it proportionally decreased in height like a pyramid made of Local Mountain stone.

The used mortar for the stone walls is a mix of lime, river sand, and water.

But for the top parts of domes and arches, red brick with the motioned size of 24 cm by 24 cm by 5 cm is used.

In addition, we can see lime plaster work on the ceiling, interior, and exterior walls.

## **Buddhist Temple in Kabul City**

The internal war between different Mujahidin parties, who got control of Kabul city in the spring of 1994, destroyed 60% of the city, including public and residential blocks, houses, monuments, hospitals, businesses, markets, historical, military, and worship buildings such as mosques and Buddhist temples.

The measurements are explained in the pictures and drawings below.



**A picture of the ruins of a Buddhist temple after the internal war**

## Buddhist Temple in Kabul City

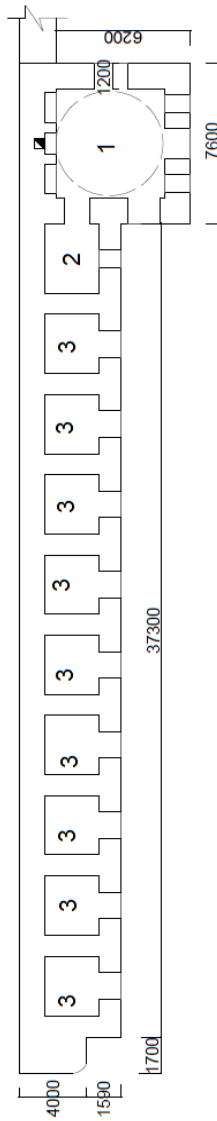

Plan of the existing Buddhist temple

## **Buddhist Temple in Kabul City**

1-Worship hall

2-Pundit room

3-Guest room



**Front elevation of the existing Buddhist temple**



**Interior picture of the worship hall in a Buddhist temple**

## Buddhist Temple in Kabul City

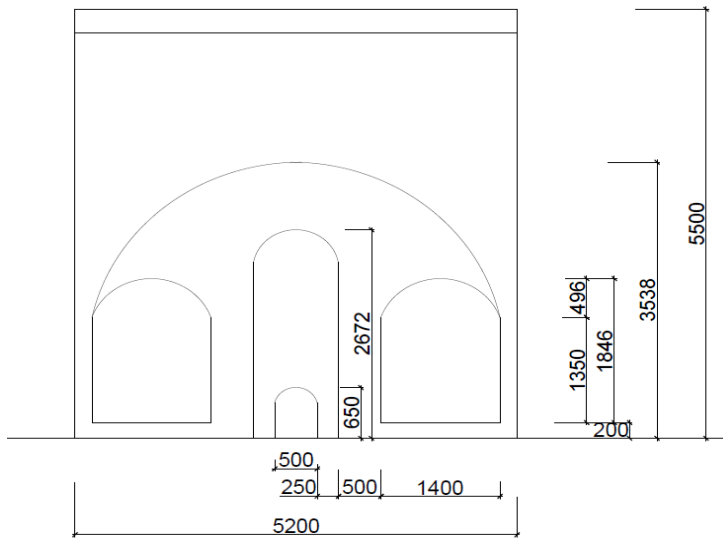

**Drawing of the inner wall (south) of the prayer hall in a Buddhist temple**



## Buddhist Temple in Kabul City

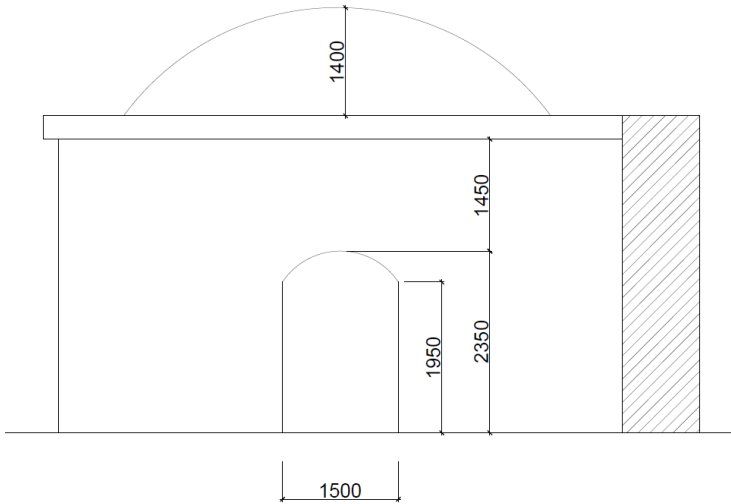

**West-side elevation of the Buddhist temple**

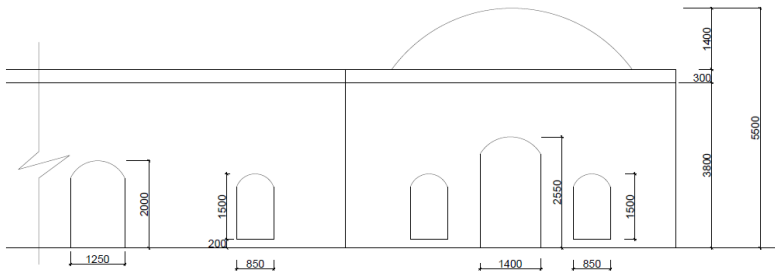

**Fragment elevation (long view) of the Buddhist temple**

## Buddhist Temple in Kabul City

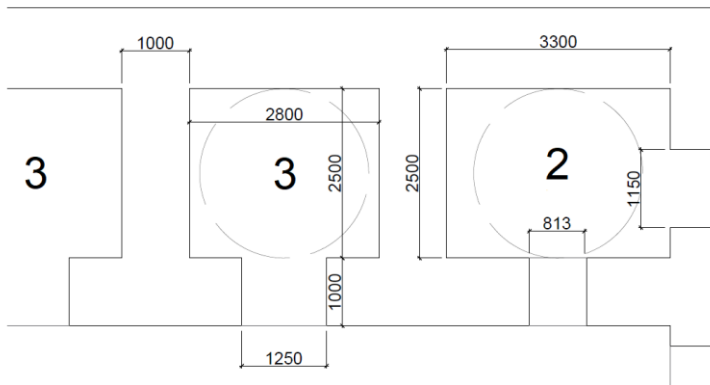

Fragment plan of the Buddhist temple

2- Pundit room

3- Guest room

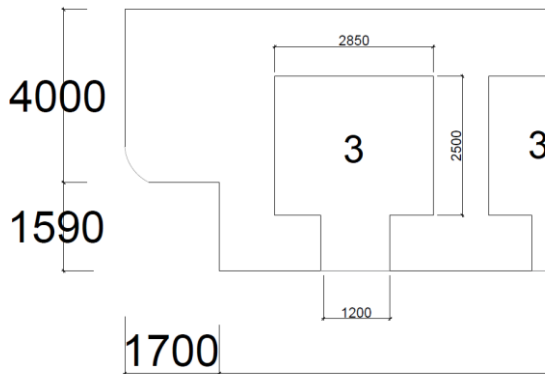

Fragment plan of the Buddhist temple

## **Buddhist Temple in Kabul City**



**North elevation of the worship hall of the Buddhist temple after renovation**

## **Buddhist Temple in Kabul City**



**Pictures of the entrance (west side) to the Buddhist temple**



**Interior pictures of the lower part of the Buddhist temple after renovation**

## **Buddhist Temple in Kabul City**



**Interior pictures of the upper part of the Buddhist temple after renovation**



**Ceiling picture of the dome of the worship hall of a of a Buddhist temple**

## **Buddhist Temple in Kabul City**



**Entrance door opening picture of the pundit room from the  
worship hall in the Buddhist temple's**

## Buddhist Temple in Kabul City



**Pictures from the worship hall to the veranda of the Buddhist temple**

## Buddhist Temple in Kabul City



Ceiling picture of one residence room of the Buddhist temple



## **Buddhist Temple in Kabul City**



**Front elevation Pictures of the Buddhist temple after renovation  
from the west**



**Front elevation Pictures of the Buddhist temple after renovation  
from the east**

## Buddhist Temple in Kabul City



**Gust room interior picture**

## **Buddhist Temple in Kabul City**



**Pictures of bricks for the renovation of a Buddhist temple**

## Buddhist Temple in Kabul City



**Front elevation Pictures of the Buddhist temple after renovation from the east**

## Buddhist Temple in Kabul City



**Front elevation Pictures of the Buddhist temple after renovation from the east**

## Buddhist Temple in Kabul City



**Front elevation Pictures of the Buddhist temple after renovation  
from the north**

## Buddhist Temple in Kabul City



**Roof panorama (covering) of the Buddhist temple during renovation**

## **Buddhist Temple in Kabul City**



**Worship hall roof panorama (covering) of the Buddhist temple during renovation**



## Buddhist Temple in Kabul City



**Guest room roof panorama (covering) of the Buddhist temple during renovation**

## Buddhist Temple in Kabul City



**Guest room roof panorama (covering) of the Buddhist temple during renovation**

## **Buddhist Temple in Kabul City**



**Panoramic pictures of the Buddhist temple after renovation**

## **Buddhist Temple in Kabul City**

It is worth mentioning that the Buddhist temple building is 270 meters above Kabul city level and 2061 meters above sea level; it is located on the slopes of Shir Darvaza Mountain, on the upper part of the Khwaja Safa Recreational Complex, and near the natural water spring that the people of the nearby villages use for their needs. It seems that dozens of people visit the above complex every day to have fun and see the existing buildings.

But on the first day of the New Year (Nowruz), hundreds of residents of the lower areas, Shur bazar, and other places of Kabul, including Hindus and Muslims, get together as close friends and good neighbors and have fun with sweets prepared in Shur bazar, such as Jalebi and Mithai with green tea, and return to their homes in the evening.

If we compare the building materials of the Buddhist temple along with the wall of Kabul Balahesar, which is not far away and on the east side of the same temple on the hill connected to Shir Darvaza mountain, especially the remaining temples in its inner area, it can be concluded that both buildings were built in the 5th century AD.

## **Buddhist Temple in Kabul City**

It seems that the people who were living around those places were Buddhists.

## **Buddhist Temple in Kabul City**

### **Sources:**

1. Mud and Wood Architecture (Old City of Kabul)
2. Field research

## **Buddhist Temple in Kabul City**

### **Published book list**

1. Architecture of Afghanistan
2. Information, design principles, and rules in architecture (hospitals department)
3. Golden guide

(For professors of technical and construction institutes in Afghanistan)

4. Technical drawing (a step towards the world of engineering) first volume
5. Technical drawing (a step towards the world of engineering), second volume
6. Information, design principles, and rules in architecture (administrative section)
7. The pure architecture of Kabul city (Morad Khani)
8. Architecture of Kabul City (Bi Bi Mehro)
9. Afghanistan in the century of technology
10. Climate zoning and earthquakes in Afghanistan
11. Charity is ongoing in the engineering world.
12. Pure learning, from design to supervision  
The first volume (1990–2021)
13. A true story with architectural scale

## **Buddhist Temple in Kabul City**

14. Escape from the country with documentary images
15. The role of Muslim scientists in architecture and engineering
16. Mud work in Afghanistan
17. The establishment of the first mosques by Afghans in Australia
18. Pure learnings from design to supervision

The second volume (1990–2021)

19. Jam minaret is an inspiration for Qutub Minar
20. Jam Minaret is Inspiration for Qutub Minar
21. Pure learning, from design to supervision

The third volume (1990–2021)

22. Jam minaret or Kalyan (Klan)
23. Mud and wood architecture (architecture of the old city of Kabul), volume I
24. Mud and Wood Architecture (Architecture of the Old City of Kabul), Volume II
25. Mud and wood architecture (architecture of the old city of Kabul), volume III
26. Where there is no law, (irregularity in Afghan architecture)



## **Buddhist Temple in Kabul City**

27. Modern mosques (past and present)
28. Make it soon. (Mud bamboo is earthquake-resistant.)
29. Information, design principles, and rules in architecture (Mosques section)
30. Information, design principles, and rules in architecture (school section)
31. The art and craft of wood in Morad Khani
32. The art and craft of goldsmiths in Murad Khani
33. Nothing (forty true stories)
34. The pure architecture of Kabul city (Presentation at Kabul Polytechnic University)
35. 40- forty
36. Majnoon and Gulchen (Pashto novel)
37. In search (Dari novel)
38. Differences bring differences (picture book).
39. A collection of religious lessons by Maulvi Sahib Khairullah Makhdoom (first volume)
40. The snow melts.
41. Technical Drawing (A Step Towards the World of Engineering, Volume 3)
42. Arzo and Omid (Dari novel)
43. Old Hunter (Pashto Novel)
44. Funny animals (Pashto novel)

## **Buddhist Temple in Kabul City**

- 45.The beginning of Islamic architecture
- 46.Funny animals (Dari novel)
- 47.A collection of religious lessons by Maulvi Sahib Khairullah Makhdoom (Volume II)
- 48.A Lover of the Flute in Kacha Garay (Pashto novel)
- 49.Architecture of Hashmat Khan Castle
- 50.The love of an Afghan boy and an Azari girl
- 51.Architecture of dry gardens and parks
- 52.Students love a teacher in a class (Pashto novel).
- 53.The Love of the Miller (Pashto novel)
- 54.Construction progress in the Islamic system
- 55.Shepherdess (Pashto novel)
- 56.Illiterate Sage (Pashto novel)
- 57.Circulation of Love (Pashto novel)
- 58.(BIM) in my own language (the world's fastest procedure for architects and engineers).
- 59.A collection of religious lessons by Maulvi Sahib Khairullah Makhdoom (Volume III)
- 60.Seydu and Eidu: childhood friends (Pashto novel)
- 61.One Month Bride (Pashto novel)
- 62.Drops of Necklaces (A Few Stories of a Man)

## **Buddhist Temple in Kabul City**

63. The pure architecture of Kabul city (Morad Khani)
64. Little Girl Merchant (Pashto novel) Kabul city architecture: Bi Bi Mehro
65. Famous Drug User (Dari Novel)
66. Scary Flood (Pashto novel)
67. Hardworking judge (Pashto novel)
68. The difference between old and new mosques
69. Mother Killer (Pashto Novel)
70. Ender's mother (Pashto novel)
71. A collection of religious lessons by Maulvi Sahib Khairullah Makhdoom (Volume 4)
72. Crazy Mullah (Pashto novel)
73. Young Martyr (Pashto novel)
74. Warm quilt (Pashto Novel)
75. Nurak Aka (Pashto Novel)
76. Gharibak (Pashto novel)
77. The Sweet and Hot of Life (Pashto Novel)
78. Al-Ma'a (Pashto novel)
79. A collection of religious lessons by Maulvi Sahib Khairullah Makhdoom (the fifth volume)
80. Literary sticks (in Dari and Pashto)
81. Municipality worker (Pashto Novel)
82. An undersoil city near the Aynak copper mine (in Pashto)

## **Buddhist Temple in Kabul City**

83. An underground city near the Aynak copper mine (in Dari)

84. Containerized buildings (in Dari language)

85. Containerized buildings (in Pashto)

86. Buddhist Temple in Kabul City

## **Buddhist Temple in Kabul City**

### **Books in progress**

1. The art of calligraphy and miniature in Murad Khani
2. Clay art in Morad Khani
3. Crazy wolf
4. White crow
5. Hot oven
6. Gray monkey
7. Bird in the cage
8. Untimely rain
9. End of life

## **Buddhist Temple in Kabul City**

### **If time and possible**

1. Mud work (Pakhsa) in Afghanistan in English
2. History of Afghan architecture
3. Skyscraper houses
4. Relationship between the past, present, and future in architecture
5. 5. Talent, speed, and economy in Afghan architecture
6. Devil of Light
7. Memories



**Get more e-books from [www.ketabton.com](http://www.ketabton.com)  
Ketabton.com: The Digital Library**